



5337 E019

NRCS CMM Div. – Approval of swimming aids

Controlled by:	Specialist (CMM)	Signature:	
Approved by:	Acting Executive Manager: NPP	Signature:	
Date of approval:	4 - March - 2011		
Date of implementation:	4 - March - 2011 04/03/2011		

## Contents

		<b>Page</b>
1	PURPOSE .....	4
2	SCOPE .....	4
3	REFERENCES.....	4
	3.1 Legislation.....	4
	3.2 Standards .....	4
	3.3 Policies, manuals and procedures .....	4
4	DEFINITIONS & ABBREVIATIONS .....	5
	4.1 Definitions.....	5
	4.2 Abbreviations .....	5
5	GENERAL RULES .....	6
	5.1 Proof of compliance .....	6
	5.2 Samples .....	6
	5.3 Data .....	6
	5.4 Records.....	6
	5.5 Communications .....	6
	5.6 Inspection safety .....	7
6	APPLICATION FOR APPROVAL.....	8
7	TYPE-EXAMINATION .....	10
8	APPROVAL REJECTED .....	12
9	APPROVAL GRANTED .....	13
10	EXTENSION OF APPROVAL .....	15
11	REPLACEMENT AND WITHDRAWAL.....	19
12	FORMS .....	19
13	ANNEXURES, APPENDICES & ATTACHMENTS .....	19
	Annexure A: NRCS form No. VC9090-A .....	20
	Annexure B: NRCS form No. VC9090-B .....	21
	Appendix B1: NRCS form No. VC9090-B1 .....	22
	Appendix B2: NRCS form No. VC9090-B2 .....	23

---

Appendix B3: NRCS form No. VC9090-B3 .....	24
Appendix B4: NRCS form No. VC9090-B4 .....	25
Appendix B5: NRCS form No. VC9090-B5 .....	26
Appendix B6: NRCS form No. VC9090-B6 .....	27
Annexure C: NRCS form No. VC9090-C .....	28
Annexure D: Application documents.....	29
Annexure E: Approval of swimming aid: APPROVAL REJECTED .....	30
Annexure F: Arrangement of approval number .....	31
AA33: Goods dispatch and receipt note .....	Attached
<i>NRCS Inspection Report</i> for swimming aids .....	Attached
<i>NRCS Letter of Authority APPROVAL GRANTED certificate</i> for swimming aids .....	Attached
<i>NRCS Letter of Authority APPROVAL EXTENDED certificate</i> for swimming aids .....	Attached
14 REVISION PARTICULARS.....	32

## 1 Purpose

This document describes the procedure that shall be used by the NRCS CMM Division for the approval of swimming aids in terms of VC9090:2009.

## 2 Scope

This document applies to the following:

- a) All staff members of CMM involved in the approval of swimming aids.
- b) All swimming aids as covered by the scope of VC9090:2009.

This procedure covers the following:

- a) General rules that are applicable to the approval of swimming aids.
- b) Application for approval of swimming aids.
- c) Type-examination of swimming aids.
- d) Rejection of unacceptable applications for the approval of swimming aids.
- e) Approval of swimming aids.
- f) Extension of approval of swimming aids.

## 3 References

This document incorporates by dated or undated reference, provisions from other publications. These normative references are cited at the appropriate places in the text. For dated references, subsequent amendments to or revisions of any of these publications apply to this document only when incorporated in it by amendment or revision. For undated references the latest edition of the publication referred to applies.

### 3.1 Legislation

Compulsory Specification for swimming aids (herein referred to as VC9090:2009) as published by Government Notice No. R. 91 (Government Gazette No. 31844) of 6 February 2009.

National Regulator for Compulsory Specifications Act, 2008 (Act No. 5 of 2008)

Regulation 2 relating to the payment of fees in the form of levies as published by Government Notice No. R. 924 (Government Gazette No. 33615) of 15 October 2010.

### 3.2 Standards

SANS 17025: *'General requirements for the competence of testing and calibration laboratories'*

SANS 53138-1: *'Buoyant aids for swimming instruction, Part 1: Safety requirements and test methods for buoyant aids to be worn'*

SANS 53138-3: *'Buoyant aids for swimming instruction, Part 3: Safety requirements and test methods for swim seats to be worn'*

### 3.3 Policies, manuals and procedures

Divisional Manual No. CMM M003: *'Quality management system'*

## **4 Definitions & abbreviations**

### **4.1 Definitions**

*Approval* is a confirmation by the NRCS that a type of swimming aid satisfies the requirements of VC9090:2009.

*Inspector* is a staff member of CMM responsible for the type-examination of swimming aids.

*Manager: Approvals* of the NRCS CMM Division.

### **4.2 Abbreviations**

CMM: NRCS Chemicals, Mechanical & Materials Division

## 5 General rules

### 5.1 Proof of compliance

#### 5.1.1 *Criteria*

5.1.1.1 Class A buoyant aids for swimming instruction shall be examined for compliance against the requirements of the latest edition of SANS 53138-3.

5.1.1.2 Class B buoyant aids for swimming instruction shall be examined for compliance against the requirements of the latest edition of SANS 53138-1.

#### 5.1.2 *Evidence*

5.1.2.1 Only test reports from a testing authority that has been accredited in accordance with SANS 17025 by a signatory to the International Laboratory Accreditation Co-Operation's Mutual Recognition Agreement shall be accepted as proof of compliance with the safety requirements of SANS 53138. No approval certificates shall be accepted.

5.1.2.2 Test reports shall satisfy the requirements of the latest edition of SANS 17025.

### 5.2 Samples

5.2.1 Samples for the purpose of this procedure shall be stored in accordance with paragraph 11.4.1 of Divisional Manual No. CMM M003.

5.2.2 An AA33 form shall be completed and issued to the applicant:

- a) On receipt of application documents, technical files and reference samples from the applicant.
- b) When the applicant or his agent collects application documents, technical files and reference samples from the NRCS.
- c)

A copy of the AA33 form shall be kept in the relevant client file or product file.

### 5.3 Data

5.3.1 *Technical File Database / Technical File Database - PPE* is stored on the NRCS computer network and shall be maintained by the *Manager: Approvals*.

5.3.2 *Homologation Database / Approvals Database – Swimming Aids* is stored on the NRCS computer network and shall be maintained by the *Manager: Approvals*.

### 5.4 Records

5.4.1 Product files shall be kept in room C225 until withdrawal of approval. The *Manager: Approvals* shall be responsible for the maintenance of these product files.

5.4.2 All records pertaining to an application for approval of a type of swimming aid shall be kept in the applicable type-examination file. Records shall be kept for all documentation generated and received during the execution of this procedure. The records to be kept are identified in this procedure.

5.4.3 The client files for personal protective equipment shall be maintained in room C314A in accordance with the requirements of paragraph 12.3.2 of Divisional Manual No. CMM M003.

### 5.5 Communications

All communications may be verbal, telephonically, electronically or in writing, except where otherwise stated in this document.

## 5.6 Inspection safety

Care shall be taken when handling swimming aids for examination purposes, as a risk of personal injury may exist from possible sharp edges.

## 6 Application for approval

6.1 The applicant may request for the approval of a type of swimming aid verbally, telephonically, electronically or in writing.

6.2 The inspector shall determine if the product is covered by the scope of VC9090:2009.

### 6.3 Product not covered by VC9090:2009

6.3.1 Should it be found that the product is not covered by the scope of VC9090:2009, the inspector shall inform the applicant accordingly (electronically or in writing). The inspector shall file the following in the relevant client file (see paragraph 5.4.3):

- a) A copy of the abovementioned communication to the applicant.
- b) Documented evidence (e.g. technical specifications, instructions for use manuals, marketing material, etc.) that indicates that the product is not covered by the scope of VC9090:2009.

### 6.4 Product covered by VC9090:2009

When it is found that the product is covered by the scope of VC9090:2009, the inspector or Administration Officer: Approvals shall prepare a set of application forms as set out in Annexure D.

6.5 The inspector or Administration Officer: Approvals shall issue the application forms to the applicant electronically, in writing or by hand.

6.6 The applicant will submit the items as communicated to him by means of NRCS form No. VC9090-A to CMM for processing.

### 6.7 Preliminary examination of application

6.7.1 Upon receipt of the application by an inspector, the inspector shall do a preliminary examination of the application in order to determine whether the applicant has included the following items:

- a) Proof of payment of the non-refundable application fee for the approval of the swimming aid type.
- b) A specimen of the type of swimming aid.
- c) Completed and signed NRCS form No. VC9090-C.
- d) A technical description supported by technical drawings of the type of swimming aid.
- e) Details of the marking of the packaging for the type of swimming aid.
- f) Instructions for use.
- g) Test report/s demonstrating compliance with SANS 53138.
- h) Completed NRCS form No. VC9090-B3.

#### 6.7.2 *Incomplete application*

6.7.2.1 When it is determined that the applicant has excluded one or more of the items as listed in paragraph 6.7.1, the inspector shall inform the applicant of the following:

- a) The item/s that was/were excluded from the application.
- b) The Division will proceed with the processing of the application, but the examination of the application can only be finalised once all outstanding items have been submitted.

6.7.3 The inspector shall forward the application to the Administration Officer: Approvals for registration and a financial check.

### 6.8 Registration of application

The Administration Officer: Approvals shall take the following actions:

6.8.1 The application shall be registered in the *Technical File Database - PPE*.



6.8.2 A type-examination file shall be opened. The type-examination file and all relevant documentation in the technical file shall be marked with the technical file number.

6.8.3 The sample (when available) shall be marked with the technical file number.

## **6.9 Financial check**

6.9.1 The Administration Officer: Approvals shall ensure with the Finance Division of the NRCS that the applicant has been registered as a levy payer in terms of regulation 2 relating to the payment of fees in the form of levies as published by Government Notice No. R. 924 (Government Gazette No. 33615) of 15 October 2010.

6.9.2 The Administration Officer: Approvals shall check for the following:

- a) If the applicant has included proof of payment of the non-refundable application fee for the approval of the type of swimming aid.
- b) If the applicant's levy return forms and payments are up to date (check with the Finance Division of the NRCS).
- c) If the applicant owes any other outstanding fees to the NRCS (check with the Finance Division of the NRCS).

**6.10** When it is found that the applicant has not met his financial obligations towards the NRCS as set out in paragraph 6.9.2, the Administration Officer: Approvals shall inform the applicant electronically or in writing of the following:

- a) The application for the approval of the type of swimming aid will not be considered, because of the outstanding proof of payment of the non-refundable application fee or other outstanding fees.
- b) The application will be rejected if no proof of payment of the outstanding fee/s has been received within three (3) weeks from the date of notification.

6.10.1 The Administration Officer: Approvals shall file a copy of the notification in the relevant type-examination file.

6.10.2 The actions as set out in paragraph 8 may be taken when no proof of payment of the outstanding fee/s has been received within the three (3) week notification period.

**6.11** When it is found that the applicant has met his financial obligations towards the NRCS, the Administration Officer: Approvals shall take the following actions:

6.11.1 The Administration Officer: Approvals shall request the Finance Division to invoice the applicant for the received proof of payment of the non-refundable application fee. The Administration Officer: Approvals shall file a copy of the invoice indicating full payment of the application fee in the relevant type-examination file.

6.11.2 The Administration Officer: Approvals shall forward the type-examination file to the inspector who has been nominated by the Manager: Approvals to examine the application.

## 7 Type-examination

7.1 The application shall be examined to establish whether the applicant has submitted the items as communicated to him by means of NRCS form No. VC9090-A.

The technical file and its contents shall be examined for completeness and correctness in accordance with the requirements of NRCS form No. VC9090-B.

The technical file and its contents shall be examined to establish its suitability with respect to demonstrating compliance with the applicable requirements of paragraphs 3.1, 3.2 and 3.5 of VC9090:2009.

The results of the examination shall be recorded in a *NRCS Inspection Report* for swimming aids as attached to this document.

### 7.2 Unacceptable technical file

The inspector shall take the following actions should the technical file and its contents not meet the criteria as set out in paragraph 7.1:

7.2.1 The inspector shall notify the applicant electronically or in writing of the following:

- a) The applicant shall be notified of the problems with the technical file and requested to resubmit a corrected file within four (4) months from the date of notification.
- b) The technical file and reference sample (when available) must be collected at the NRCS premises for correction purposes.

7.2.2 The inspector shall file copies of the notification and technical file in the type-examination file.

7.3 The actions as set out in paragraph 8 shall be taken should the applicant fail to resubmit the corrected technical file within the four (4) month period.

7.4 The following actions shall be taken when it is found that the resubmitted technical file still did not meet the criteria as set out in paragraph 7.1:

7.4.1 One copy of the technical file shall be made and kept in the type-examination file.

7.4.2 The inspector shall invite the applicant to a meeting at the NRCS premises. The purpose of the meeting will be the following:

- a) Explanation of the findings on the technical file.
- b) The applicant will be supplied with a copy of the findings.
- c) The inspector shall return the technical file and reference sample (when available) to the applicant during the meeting for correction purposes.
- d) The applicant will be requested to resubmit a corrected technical file within three (3) weeks from the date of the meeting.

7.4.3 The actions as set out in paragraph 8 shall be taken should:

- a) the applicant fail to resubmit the corrected technical file within the three (3) week period after the meeting date or;
- b) when it is found that the resubmitted technical file still did not meet the criteria as set out in paragraph 7.1.

### 7.5 Acceptable technical file

The following actions shall be taken when the technical file meets the criteria as set out in paragraph 7.1:

7.5.1 The inspector shall examine the reference sample of the swimming aid type to verify that it has been produced in accordance with the technical file. The results of the examination shall be recorded in the *NRCS Inspection Report* for swimming aids.

**7.6 Unacceptable reference sample**

7.6.1 The actions as set out in paragraph 8 shall be taken should the reference sample not meet the criteria as set out in paragraph 7.5.1.

**7.7 Acceptable reference sample**

7.7.1 The actions as set out in paragraph 9 shall be taken when the sample meets the criteria as set out in paragraph 7.5.1.

## **8 APPROVAL REJECTED**

- 8.1** The *inspector* shall complete and sign the inspection report and include it in the type-examination file.
- 8.2** The *inspector* shall prepare a letter as set out in Annexure E and include it in the type-examination file.
- 8.3** The *inspector* shall forward the type-examination file to the *Manager: Approvals* for review.
- 8.4** Once satisfied with the contents of the inspection report and letter, the *Manager: Approvals* shall sign the aforementioned documents.
- 8.5** The *inspector* shall file copies of the following documents in the type-examination file:
- a) The signed letter in paragraph 8.4;
  - b) *NRCS Inspection Report*;
  - c) Technical file (when available).
- 8.6** The *inspector* shall ensure that the signed letter in paragraph 8.4 is forwarded to the applicant electronically or by mail.
- 8.7 Close-out of type-examination task**
- 8.7.1** The *inspector* shall file the type-examination file in the relevant client file.

## 9 APPROVAL GRANTED

9.1 The *inspector* shall complete and sign the inspection report. The inspection report shall be filed in the type-examination file.

9.2 The *inspector* shall register the type of swimming aid in the *Approvals Database – Swimming Aids* and shall allocate a type approval number.

### 9.2.1 *Type approval number*

The first two digit groupings of the approval number shall indicate **NRCS/9090/**. The last digit grouping of the approval number shall be a **sequential number**. Annexure F to this document gives an example of the arrangement of the approval number for swimming aids.

### 9.2.2 *Type-identifying information*

The type of swimming aid shall be described as follows in the *Approvals Database – Swimming Aids*:

[Name or trademark of the manufacturer, importer or supplier as marked on the type of swimming aid]  
[Type-identifying name or number] [Classification in accordance with relevant product specification standard]

## 9.3 Approval certificate

9.3.1 The *inspector* shall compile a *NRCS Letter of Authority APPROVAL GRANTED certificate* as attached to this document.

9.3.2 The *inspector* shall mark the following documents with the allocated type approval number and initial it:

- a) Drawings, diagrams, plans and photographs of the type of swimming aid;
- b) Details of the marking of the type of swimming aid;
- c) Details of the marking of the packaging for the type of swimming aid;
- d) Information for users for the type of swimming aid;
- e) NRCS form No. VC9090-B2 as set out in Appendix B2;
- f) NRCS form No. VC9090-B3 that was completed and submitted by the applicant.

The documents shall be described in the *NRCS Letter of Authority APPROVAL GRANTED certificate*.

9.3.3 The *inspector* shall emboss the golden star on the certificate with the NRCS emblem embossment machine.

9.3.4 The *inspector* shall sign the prepared *NRCS Letter of Authority APPROVAL GRANTED certificate* and include it in the type-examination file.

9.4 The *inspector* shall forward the type-examination file to the *Manager: Approvals* for review.

9.5 Once satisfied with the contents of the inspection report and *NRCS Letter of Authority APPROVAL GRANTED certificate*, the *Manager: Approvals* shall sign the aforementioned documents.

9.6 The *inspector* shall compile the following:

<p><i>ORIGINAL NRCS LOA APPROVAL GRANTED certificate</i></p> <p style="text-align: center;">↓</p> <p>Attach to ORIGINAL certificate: COPIES of marked documents in paragraph 9.3.2.</p> <p style="text-align: center;">↓</p> <p>Submit to applicant.</p>	<p><i>COPY of NRCS LOA APPROVAL GRANTED certificate</i></p> <p style="text-align: center;">↓</p> <p>Attach to COPY of certificate: ORIGINAL marked documents in paragraph 9.3.2.</p> <p style="text-align: center;">↓</p> <p>File in type-examination file.</p>
--	---

- 9.7** The *inspector* shall notify the applicant in writing or by e-mail that the approved *NRCS LOA APPROVAL GRANTED certificate* and reference sample must be collected at the NRCS premises. The *inspector* shall file a copy of the aforementioned notification in the type-examination file.
- 9.8** The *inspector* shall open a product file for the approved type of swimming aid and mark it with the allocated type approval number.
- 9.9** The *inspector* shall file the type-examination file in the product file for the approved type of swimming aid.
- 9.10** The *inspector* shall store the product file in room C225 in accordance with the requirements of paragraph 5.4.1.

## 10 Extension of approval

### 10.1 Notification

10.1.1 In accordance with paragraph 3.4 of VC9090:2009 and the terms and conditions of issue of a *NRCS Letter of Authority APPROVAL GRANTED certificate* for swimming aids the holder of an approval shall notify the NRCS of any modifications that will be made to the type of swimming aid itself, its control of conformity of production, its design and materials, markings, packaging material and information for users that shall accompany it when placed on the market as required by the appropriate South African National Standard.

10.1.2 The *inspector* shall establish the nature of the changes made to the approved type, and request in writing or electronically the following from the applicant:

- a) A letter from the applicant indicating the modifications that will be made to the approved type of swimming aid.
- b) Proof of payment of the current non-refundable application fee for the extension of approval of a swimming aid type as published in the Government Gazette in terms of section 14(3)(b) of Act No. 5 of 2008.
- c) Documented evidence as per NRCS form No. VC9090-B indicating such changes.
- d) A specimen of the type of swimming aid if modifications were made to the swimming aid itself, its design and materials and/or markings.

### 10.2 Registration of application

10.2.1 On receipt of the requested items as per paragraph 10.1.2, the Administration Officer: Approvals shall take the following actions:

10.2.1.1 The application shall be registered in the *Technical File Database - PPE*.

10.2.1.2 A type-examination file shall be opened. The type-examination file and all relevant documentation in the technical file shall be marked with the technical file number.

10.2.1.3 The sample (when available) shall be marked with the technical file number.

### 10.3 Financial check

10.3.1 The Administration Officer: Approvals shall check for the following:

- a) If the applicant has included proof of payment of the non-refundable application fee for the extension of approval of the type of swimming aid.
- b) If the applicant's levy return forms and payments are up to date (check with the Finance Division of the NRCS).
- c) If the applicant owes any other outstanding fees to the NRCS (check with the Finance Division of the NRCS).

10.4 When it is found that the applicant has not met his financial obligations towards the NRCS as set out in paragraph 10.3.1, the Administration Officer: Approvals shall inform the applicant electronically or in writing of the following:

- a) The application for the extension of approval of the type of swimming aid will not be considered, because of the outstanding proof of payment of the non-refundable application fee or other outstanding fees.
- b) The application will be rejected if no proof of payment of the outstanding fee/s has been received within three (3) weeks from the date of notification.

10.4.1 The Administration Officer: Approvals shall file a copy of the notification in the relevant type-examination file.

- 10.4.2 The actions as set out in paragraph 8 may be taken when no proof of payment of the outstanding fee/s has been received within the three (3) week notification period.
- 10.5** When it is found that the applicant has met his financial obligations towards the NRCS, the Administration Officer: Approvals shall take the following actions:
- 10.5.1 The Administration Officer: Approvals shall request the Finance Division to invoice the applicant for the received proof of payment of the application fee. The Administration Officer: Approvals shall file a copy of the invoice indicating full payment of the application fee in the relevant type-examination file.
- 10.5.2 The Administration Officer: Approvals shall forward the type-examination file to the inspector who has been nominated by the *Manager: Approvals* to examine the application.

## **10.6 Type-examination**

- 10.6.1 The technical file and its contents shall be examined to establish its suitability with respect to demonstrating the following:
- a) Modifications made to the type of swimming aid itself, its control of conformity of production, its design and materials, markings, packaging material and information for users that shall accompany it when placed on the market as required by the appropriate South African National Standard.
  - b) Compliance with the applicable requirements of paragraphs 3.1, 3.2 and 3.5 of VC9090:2009 as a result of the modifications made to the type of swimming aid.

The results of the examination shall be recorded in a *NRCS Inspection Report* for swimming aids as attached to this document.

## **10.7 Unacceptable technical file**

The inspector shall take the following actions should the technical file and its contents not meet the criteria as set out in paragraph 10.6.1:

- 10.7.1 The inspector shall notify the applicant electronically or in writing of the following:
- a) The applicant shall be notified of the problems with the technical file and requested to resubmit a corrected file within four (4) months from the date of notification.
  - b) The technical file and reference sample (when available) must be collected at the NRCS premises for correction purposes.
- 10.7.2 The inspector shall file copies of the notification and technical file in the type-examination file.
- 10.7.3 The actions as set out in paragraph 8 shall be taken should the applicant fail to resubmit the corrected technical file within the four (4) month period.
- 10.7.4 The following actions shall be taken when it is found that the resubmitted technical file still did not meet the criteria as set out in paragraph 10.6.1:
- 10.7.4.1 One copy of the technical file shall be made and kept in the type-examination file.
- 10.7.4.2 The inspector shall invite the applicant to a meeting at the NRCS premises. The purpose of the meeting will be the following:
- a) Explanation of the findings on the technical file.
  - b) The applicant shall be supplied with a copy of the findings.
  - c) The inspector shall return the technical file and reference sample (when available) to the applicant during the meeting for correction purposes.
  - d) The applicant shall be requested to resubmit a corrected technical file within three (3) weeks from the date of the meeting.



- 10.7.4.3 The actions as set out in paragraph 8 shall be taken should:
- a) the applicant fail to resubmit the corrected technical file within the three (3) week period after the meeting date or;
  - b) when it is found that the resubmitted technical file still did not meet the criteria as set out in paragraph 10.6.1.

## **10.8 Acceptable technical file**

The following actions shall be taken when the technical file meets the criteria as set out in paragraph 10.6.1:

- 10.8.1 When modifications were made to the type of swimming aid itself, its design and materials and/or markings, the inspector shall examine a reference sample of the type of swimming aid in order to verify that it has been produced in accordance with the modifications demonstrated in the technical file. The results of the examination shall be recorded in the *NRCS Inspection Report* for swimming aids.

## **10.9 Unacceptable reference sample**

- 10.9.1 The actions as set out in paragraph Approvals *Database – Swimming Aids* shall be taken should the reference sample not meet the criteria as set out in paragraph 10.8.1.

## **10.10 Acceptable reference sample**

- 10.10.1 The actions as set out in paragraph 10.11 shall be taken when the reference sample meets the criteria as set out in paragraph 10.8.1.

## **10.11 APPROVAL EXTENDED**

- 10.11.1 The inspector shall complete and sign the inspection report. The inspection report shall be filed in the type-examination file.
- 10.11.2 The *inspector* shall register the extension of approval of the type of swimming aid in the *Approvals Database – Swimming Aids* and shall assign a sequential “Extension No.”. The Extension Number shall be in Roman numerals, e.g. I, II, III, etc.

## **10.12 Extension of approval certificate**

- 10.12.1 The inspector shall compile a *NRCS Letter of Authority APPROVAL EXTENDED certificate* for swimming aids as attached to this document.
- 10.12.2 The inspector shall mark the following documents with the appropriate type approval number and initial it:
- a) When relevant, drawings, diagrams, plans and photographs demonstrating the modifications made to the type of swimming aid itself and its design and materials.
  - b) When relevant, details of the modifications made to the marking of the type of swimming aid;
  - c) When relevant, details of the modifications made to the marking of the packaging for the type of swimming aid;
  - d) When relevant, details of the modifications made to the information for users for the type of swimming aid.
  - e) When relevant, details of the modifications made to the control of conformity of production for the type of swimming aid.

The relevant documents and alterations shall be described in the *NRCS Letter of Authority APPROVAL EXTENDED certificate*.

- 10.12.3 The inspector shall emboss the golden star on the *NRCS Letter of Authority APPROVAL EXTENDED certificate* with the NRCS emblem embossment machine.

- 10.12.4 The *inspector* shall sign the prepared *NRCS Letter of Authority APPROVAL EXTENDED certificate* and include it in the type-examination file.
- 10.13 The *inspector* shall forward the type-examination file to the *Manager: Approvals* for review.
- 10.14 Once satisfied with the contents of the inspection report and *NRCS Letter of Authority APPROVAL EXTENDED certificate*, the *Manager: Approvals* shall sign the aforementioned documents.
- 10.15 The *inspector* shall compile the following:

<p>ORIGINAL <i>NRCS Letter of Authority APPROVAL EXTENDED certificate</i></p> <p style="text-align: center;">↓</p> <p>Attach to ORIGINAL certificate: COPIES of marked documents in paragraph 10.12.2.</p> <p style="text-align: center;">↓</p> <p>Submit to applicant.</p>	<p>COPY of <i>NRCS Letter of Authority APPROVAL EXTENDED certificate</i></p> <p style="text-align: center;">↓</p> <p>Attach to COPY of certificate: ORIGINAL marked documents in paragraph 10.12.2.</p> <p style="text-align: center;">↓</p> <p>File in type-examination file.</p>
---	--

- 10.16 The *inspector* shall notify the holder of the approval in writing or by e-mail that the approved *NRCS Letter of Authority APPROVAL EXTENDED certificate* must be collected at the NRCS premises. The *inspector* shall file a copy of the aforementioned notification in the type-examination file.
- 10.17 The *inspector* shall file the type-examination file in the appropriate product file for the type of swimming aid.
- 10.18 The *inspector* shall store the product file in room C225 in accordance with the requirements of paragraph 5.4.1.

## **11 Replacement and withdrawal**

Not applicable.

## **12 Forms**

-

## **13 Annexures, appendices & attachments**

### **13.1 Annexures & appendices**

Annexure A: NRCS form No. VC9090-A.

Annexure B: NRCS form No. VC9090-B.

Appendix B1: NRCS form No. VC9090-B1.

Appendix B2: NRCS form No. VC9090-B2.

Appendix B3: NRCS form No. VC9090-B3.

Appendix B4: NRCS form No. VC9090-B4.

Appendix B5: NRCS form No. VC9090-B5.

Appendix B6: NRCS form No. VC9090-B6.

Annexure C: NRCS form No. VC9090-C

Annexure D: Application documents

Annexure E: Approval of swimming aid: APPROVAL REJECTED

Annexure F: Arrangement of approval number

### **13.2 Attachments**

AA33: Goods dispatch and receipt note

*NRCS Inspection Report* for swimming aids

*NRCS Letter of Authority APPROVAL GRANTED certificate* for swimming aids.

*NRCS Letter of Authority APPROVAL EXTENDED certificate* for swimming aids.

## Annexure A

### NRCS form No. VC9090-A

#### Application for the approval of swimming aids

##### ITEMS REQUIRED

In terms of the Compulsory Specification for swimming aids (herein referred to as VC9090:2009) as published by Government Notice No. R. 91 (Government Gazette No. 31844) of 6 February 2009.

The following items are required for an application for the approval of a type of swimming aid.

**NOTE:** All applications, including accompanying documentation, shall be in at least one of the official languages of the Republic of South Africa.

##### A Proof of payment

Proof of payment of a non-refundable application fee for the approval of a type of swimming aid as published in the Government Gazette in terms of section 14(3)(b) of the National Regulator for Compulsory Specifications Act, 2008 (Act No. 5 of 2008). The amount of the non-refundable application fee may be requested from the NRCS CMM Approvals Section:

Mrs. Tando Magolego  
MANAGER: APPROVALS  
Tel No.: +27 12 428-6375  
Fax No.: +27 12 428 6513  
E-mail: [MAGOLET@nrcs.org.za](mailto:MAGOLET@nrcs.org.za)

##### B Technical file

A technical file for the type of swimming aid as set out in NRCS form No. VC9090-B.

##### C Reference sample

At least one specimen of the type of swimming aid. The specimen shall include all the accessories that are supplied with the type of swimming aid, within the packaging, as it is placed on the market, whether or not those accessories have actually been fitted to the swimming aid.

##### D Other

**Note:** An application for the approval of a type of swimming aid will not be considered when the applicant owes any outstanding fees to the NRCS, or when the applicant has failed to comply with regulation 2 relating to the payment of fees in the form of levies as published by Government Notice No. R. 924 (Government Gazette No. 33615) of 15 October 2010.

NRCS bank account details:

The National Regulator for Compulsory Specifications (NRCS)  
ABSA Bank  
Brooklyn Branch Code: 335345  
Bank Account No.: 4072161682

NRCS Chemicals, Mechanical & Materials Division  
SABS Campus 1 Dr. Lategan Road Groenkloof Pretoria • Private Bag X25 BROOKLYN 0075 • Tel. +27 12 428-6377 • Fax. +27 12 428-6513  
[www.nrcs.org.za](http://www.nrcs.org.za)

"Protecting health, Safety, the Environment and ensuring Fair Trade"

## Annexure B

### NRCS form No. VC9090-B

#### Technical file for swimming aids

Application for the approval of swimming aids in terms of the Compulsory Specification for swimming aids (herein referred to as VC9090:2009) as published by Government Notice No. R. 91 (Government Gazette No. 31844) of 6 February 2009.

The technical file for each type of swimming aid shall consist of the following:

#### B.1 Application form

NRCS form No. VC9090-C.

*Note: The applicant shall be the manufacturer or importer of the type of swimming aid. The manufacturer or importer shall be an established legal entity within the Republic of South Africa.*

#### B.2 Technical specifications

A technical description supported by technical drawings of the type of swimming aid, indicating the following as a minimum:

- a) All component parts.
- b) Description of each component part.
- c) Material(s) used in each component part.  
*Note: See NRCS form No. VC9090-B5 for an example of a typical parts list & bill of materials for a product that will satisfy the aforementioned requirement.*
- d) Methods of assembly.  
*Note: See NRCS form No. VC9090-B4 for an example of a typical assembly diagram for a product that will satisfy the aforementioned requirement.*
- e) Markings and other information appearing on the type of swimming aid as required by the appropriate part of the latest edition of SANS 53138. The markings shall show the position intended for the approval number as required by paragraph 6 of the Compulsory Specification for swimming aids as published by Government Notice No. R. 91 (Government Gazette No. 31844) of 6 February 2009.

*Note 1: The technical drawings shall be to scale. See NRCS form No. VC9090-B6 for an example of a typical technical drawing that will satisfy the aforementioned requirement.*

*Note 2: Photographic evidence may be included in the technical file in order to support the technical specifications.*

#### B.3 Packaging

Details of the marking of the packaging for the type of swimming aid as required by the appropriate part of the latest edition of SANS 53138.

#### B.4 Information for users

Instructions for use that shall accompany the type of swimming aid as required by the appropriate part of the latest edition of SANS 53138.

#### B.5 Proof of compliance

Copies of test reports demonstrating compliance with all the relevant requirements of the appropriate part of the latest edition of SANS 53138, ensuring that all component parts and sizes have been covered.

*Note 1: Only test reports from a testing authority that has been accredited in accordance with the latest edition of SANS 17025 by a signatory to the International Laboratory Accreditation Co-Operation's Mutual Recognition Agreement shall be accepted as proof of compliance with the safety requirements of SANS 53138. No approval certificates will be accepted.*

*Note 2: Test reports shall satisfy the requirements of the latest edition of SANS 17025. See NRCS form No. VC9090-B1 for guidance.*

#### B.6 Conformity of production & routine tests

NRCS form No. VC9090-B3.

*Note: NRCS form No. VC9090-B2 must be consulted for the requirements for satisfactory arrangements in order to ensure effective control of the conformity of production in accordance with the provisions of VC9090:2009.*

#### B.7 Other

Any other materials that the applicant may wish to include in the technical file in order to support the application for approval, e.g. marketing material and photographs.

## Appendix B1

### NRCS form No. VC9090-B1

### Requirements for Test Reports

Application for the approval of swimming aids in terms of the Compulsory Specification for swimming aids (herein referred to as VC9090:2009) as published by Government Notice No. R. 91 (Government Gazette No. 31844) of 6 February 2009.

Test reports for the purpose of approval of swimming aids in terms of VC9090:2009 shall contain the following information as a minimum requirement. These requirements are based on the latest edition of SANS 17025 and must be consulted for further guidance.

A	Title: "TEST REPORT".	<input type="checkbox"/>
B	Name and address of laboratory.	<input type="checkbox"/>
C	Test report number.	<input type="checkbox"/>
D	Number of pages contained in the test report.	<input type="checkbox"/>
E	Each page shall be marked with: <ul style="list-style-type: none"> <li>• Test report number;</li> <li>• Page number.</li> </ul>	<input type="checkbox"/>
F	Name and address of the client.	<input type="checkbox"/>
G	Test and compliance Standard.	<input type="checkbox"/>
H	Product identification.	<input type="checkbox"/>
I	Test dates.	<input type="checkbox"/>
J	Test results against each relevant requirement of the Standard.	<input type="checkbox"/>
K	Statement of compliance/non-compliance.	<input type="checkbox"/>
L	Authorization signature of laboratory.	<input type="checkbox"/>
M	A statement to the effect that the results relate only to the items tested.	<input type="checkbox"/>

## Appendix B2

### NRCS form No. VC9090-B2

### Conformity of Production & Routine Tests

#### MINIMUM REQUIREMENTS FOR SATISFACTORY ARRANGEMENTS

In terms of the Compulsory Specification for swimming aids (herein referred to as VC9090:2009) as published by Government Notice No. R. 91 (Government Gazette No. 31844) of 6 February 2009.

- B2.1** Swimming aids shall be so manufactured as to conform to the type approved under VC9090:2009 by complying with the requirements prescribed in the appropriate part of the latest edition of SANS 53138.
- B2.2** In order to verify that the conditions stated in paragraph B2.1 have been met, appropriate control of the production shall be performed.
- B2.3** The holder of the approval is responsible for the conformity of production procedures and he shall in particular:
- B2.3.1** Ensure that the body as agreed to by the NRCS in paragraph B2.5.2 has access to the testing equipment needed to inspect the conformity of each approved type;
- B2.3.2** Ensure that the test results are recorded and that the annexed documents remain available for a time period of 3 years after test;
- B2.3.3** Analyse the results of each type of test in order to verify and ensure the stability of the swimming aid characteristics, making allowances for the variations of industrial production;
- B2.3.4** Ensure that for each type of swimming aid at least those tests prescribed in paragraph B2.5 of this document are carried out;
- B2.3.5** Ensure that when any samples or test pieces show non-conformity with the standard test concerned, further samples are taken and tested. All the necessary steps must be taken to restore conformity of the corresponding production.
- B2.4** The NRCS, which has granted the approval, may at any time verify the conformity control methods applied in each production facility.
- B2.4.1** At every inspection, the test records and production progress records shall be available to the visiting Inspector.
- B2.4.2** When the level of control appears unsatisfactory, or when it seems necessary to check the validity of the tests carried out in application of paragraph B2.3, the Inspector may select samples that will be sent to a technical service.
- B2.4.3** The relevant authorities may carry out all of the tests prescribed in the appropriate part of the latest edition of SANS 53138.
- B2.4.4** In cases where unsatisfactory results are found during an inspection, the NRCS may withdraw the approval granted in respect of a type of swimming aid pursuant to VC9090:2009.
- B2.5** **Minimum conditions for the control of conformity of buoyant aids for swimming instruction**
- B2.5.1** In agreement with the NRCS, one of the following bodies will undertake the control of conformity: the holder of an approval, or the manufacturer, or a technical service.  
*Note: The body that has been nominated by the applicant to undertake control of conformity shall be identified in NRCS form No. VC9090-B3.*
- B2.5.2** The holder of an approval shall ensure that the body as agreed to by the NRCS in paragraph B2.5.1 carries out conformity control on a statistical basis and by random sampling. In agreement with the NRCS, the tests can be carried out by a technical service, the manufacturer's test laboratory or the holder of an approval.
- B2.5.3** The samples shall be taken in accordance with the provisions of paragraph B2.5.5.
- B2.5.4** The specimens are taken at random and the tests to carry out are described in paragraph B2.5.5.
- B2.5.5** For the production to be considered conform, the tests of conformity control shall meet the following requirements:

Tests to be conducted	Sample size	Sampling and test frequency	Body to carry out tests
Testing in accordance with the appropriate part of the latest edition of SANS 53138. The body responsible for control of conformity shall identify the tests to be conducted and to the satisfaction of the NRCS. <i>Note: The body responsible for control of conformity shall record the tests to be conducted in accordance with the appropriate part of the latest edition of SANS 53138 in NRCS form No. VC9090-B3.</i>	As determined by the body responsible for control of conformity and to the satisfaction of the NRCS. <i>Note: The body responsible for control of conformity shall indicate the sample size for each test in NRCS form No. VC9090-B3.</i>	As determined by the body responsible for control of conformity and to the satisfaction of the NRCS. <i>Note: The body responsible for control of conformity shall indicate the sampling and test frequency for each test in NRCS form No. VC9090-B3.</i>	As agreed to by the NRCS. <i>Note: The body that has been nominated by the applicant to carry out the test shall be identified in NRCS form No. VC9090-B3.</i>

- B2.5.6** The test results described in paragraph B2.5.5 shall comply with the applicable requirements of the appropriate part of the latest edition of SANS 53138.





## Appendix B4

NRCS form No. VC9090-B4

VC9090-B4

### Technical Specifications: Assembly Diagram

Application for the approval of swimming aids in terms of the Compulsory Specification for swimming aids as published by Government Notice No. R. 91 (Government Gazette No. 31844) of 6 February 2009.

In accordance with paragraph B.2 of NRCS form No. VC0000-B a technical description supported by technical drawings of a type of swimming aid shall demonstrate the methods of assembly for the type of swimming aid. This is an example of a typical assembly diagram for a product that will satisfy the aforementioned requirement.

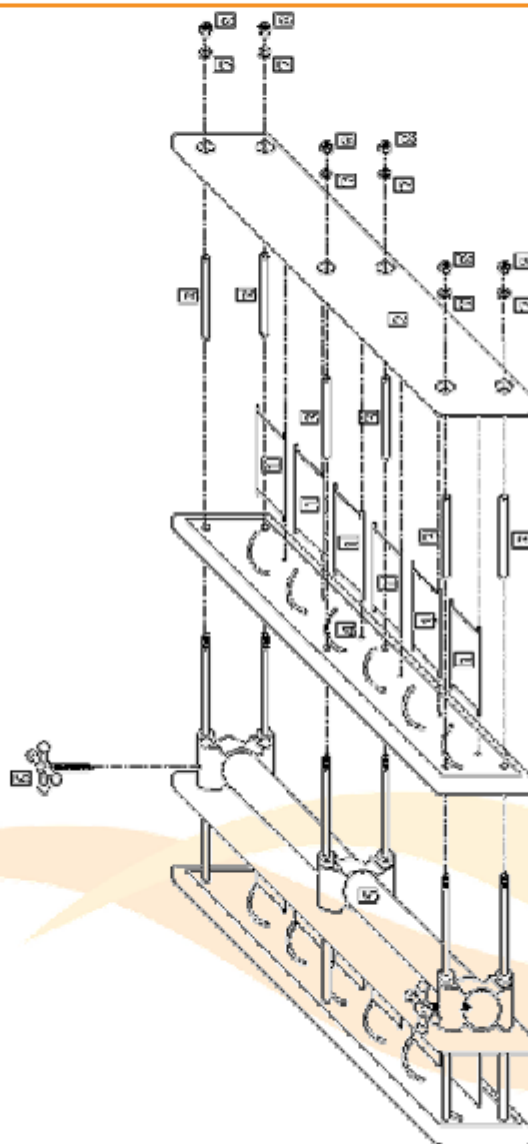

NRCS Chemicals, Mechanical & Materials Division  
SABS Campus 1 Dr. Lategan Road Groenkloof Pretoria • Private Bag X25 BROOKLYN 0075 • Tel. +27 12 428-6377 • Fax: +27 12 428-6513  
[www.nrccs.org.za](http://www.nrccs.org.za)

"Protecting health, Safety, the Environment and ensuring Fair Trade"

© NRCS Rev. 03/10/2010

## Appendix B5

### NRCS form No. VC9090-B5

### Technical Specifications: Bill of Materials

Application for the approval of swimming aids in terms of the Compulsory Specification for swimming aids as published by Government Notice No. R. 91 (Government Gazette No. 31844) of 6 February 2009.

In accordance with paragraph B.2 of NRCS form No. VC0000-B a technical description supported by technical drawings of a type of swimming aid shall indicate the material(s) used in each component part for the type of swimming aid. This is an example of a typical parts list & bill of materials for a product that will satisfy the aforementioned requirement.

Part No.	Designation	Qt.	Material
1	Blade	12	Thermoplastic
2	Left-facing blade frame	2	Thermoplastic and elastomer
3	Spacer	12	Thermoplastic
4	Right-facing blade frame	2	Thermoplastic and elastomer
5	Connecting frame	1	Non-ferrous metal
6	Setscrew	2	Non-ferrous metal
7	Washer	12	Non-ferrous metal
8	Hexagon nut ISO 4032 - M8 - CU7	12	Non-ferrous metal

**Appendix B6**

**NRCS form No. VC9090-B6**

**VC9090-B6**

**Requirements for Technical Drawings**

Application for the approval of swimming aids in terms of the Compulsory Specification for swimming aids as published by Government Notice No. R. 91 (Government Gazette No. 31844) of 6 February 2009.

In accordance with paragraph B.2 of NRCS form No. VC0000-B the technical specifications for a type of swimming aid shall include technical drawings for each component part of the type of swimming aid. In order to demonstrate the dimensions of each component part, such technical drawings shall be to scale. This is an example of a typical technical drawing of a component part for a product that will satisfy the aforementioned requirement.

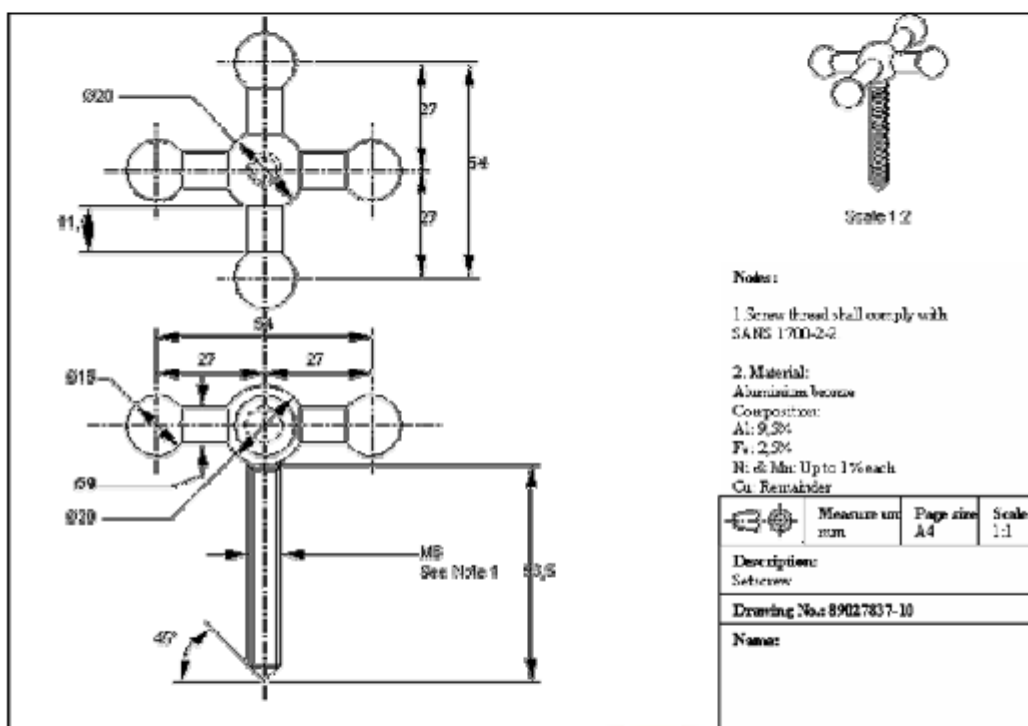

## Annexure C

### NRCS form No. VC9090-C

### Application for the approval of a type of swimming aid

In terms of the Compulsory Specification for swimming aids as published by Government Notice No. R. 91 (Government Gazette No. 31844) of 6 February 2009.

Technical file No.:	<b>NRCS use only</b>	Date of Issue:
---------------------	----------------------	----------------

*NOTE: This form shall be completed in full for each type of swimming aid submitted.*

<b>Part A: Applicant's details</b>		
Applicant's name:		
Applicant's company registration No.:		
Contact person:	Position in company:	
Tel.:	Fac:	E-mail:

<b>Part B: Importer's details</b>		
Importer's name:		
SARS Importers Code:		
Postal address:		
Physical address:		

<b>Part C: Manufacturer's details</b>		
Manufacturer's name:		
Postal address:		
Physical address:		

<b>Part D: Type-identifying information</b>							
Name or trademark of the manufacturer, importer or supplier as marked on the type of swimming aid:							
Type-identifying name or number:							
Buoyant aid for swimming instruction				according to SANS 53136-1, -2, -3			
APPLICATION	CLASS	SIZE in kg					
		≤ 11	11 - 15	15 - 18	18 - 30	30 - 60	60 ≤
to introduce the wearer to the water, passive user (worn)	A						
to introduce the wearer to swimming strokes, active user (worn)	B						
to be held and to improve part of a stroke, active user (held)	C						
For orientation only. Rough correlation body mass – age group: ≈ 11kg = 1 year; 11 to 15kg = 1 to 2 years; 15 to 18kg = 2 to 3 years; 18 to 30kg = 3 to 6 years; 30 to 60kg = 6 to 12 years							

<b>Part E: Management declaration</b>		
I hereby certify for and on behalf of the applicant that the information as contained in this application and accompanying product technical file is complete and correct in all respects, and is representative of the type of swimming aid submitted for approval.		
Signature:	Name:	
Position in company:	Date:	

NRCS Chemicals, Mechanical & Materials Division  
 SABS Campus 1 Dr. Lategan Road Groenkloof Pretoria • Private Bag X25 BROOKLYN 0075 • Tel. +27 12 428-6377 • Fax. +27 12 428-6513  
[www.nrccs.org.za](http://www.nrccs.org.za)

**"Protecting health, Safety, the Environment and ensuring Fair Trade"**

## Annexure D

### Application documents

A set of application documents shall consist of the following:

- D.1** NRCS form No. VC9090-A as set out in Annexure A.
- D.2** NRCS form No. VC9090-B as set out in Annexure B.
- D.3** NRCS form No. VC9090-B1 as set out in Appendix B1.
- D.4** NRCS form No. VC9090-B2 as set out in Appendix B2.
- D.5** NRCS form No. VC9090-B3 as set out in Appendix B3.
- D.6** NRCS form No. VC9090-B4 as set out in Appendix B4.
- D.7** NRCS form No. VC9090-B5 as set out in Appendix B5.
- D.8** NRCS form No. VC9090-B6 as set out in Appendix B6.
- D.3** NRCS form No. VC9090-C as set out in Annexure C.

**Annexure E**

**Approval of swimming aid: APPROVAL REJECTED**



Your ref:  
 Our ref.: **Approval of swimming aid - APPROVAL REJECTED**  
 Encures:  
  
 Technical file No.:  
 Date: 14/12/2009  
 Page: 1 of 1

«Company»  
 Attention: «Title» «First» «Last»  
 «Address»  
 «City»  
 «Zip/Postal Code»  
 «Country»

Dear Sir/Madam

**Approval of swimming aid: APPROVAL REJECTED**

You are hereby notified that the application for the approval of the following type of swimming aid has been rejected:

Swimming aid type: [Name or trademark of the manufacturer, importer or supplier as marked on the type of swimming aid]  
 [Type-identifying name or number] [Classification in accordance with relevant product specification standard]

Please refer to the following NRCS Inspection Report for the type-examination results:

NRCS Inspection Report No. XXX

The NRCS Inspection Report, technical file<sup>1</sup> and reference sample<sup>2</sup> must be collected at the following premises:



NRCS Head Office  
 SABS Campus  
 1 Dr. Lategan Road  
 Greenloof  
 Pretoria

The NRCS Inspection Report, technical file<sup>3</sup> and reference sample<sup>4</sup> will be disposed of if not collected within six (6) months from the date of this notification.

Yours faithfully,

T. Magolegn (Mrs.)  
 MANAGER: APPROVALS  
 NRCS CMM Division

<sup>1</sup> When available,  
<sup>2</sup> When available,  
<sup>3</sup> When available,  
<sup>4</sup> When available.

Head Office  
 SABS Campus 1 Dr. Lategan Road Greenloof Pretoria  
 NRCS Private Bag 225, Bracken 0001  
 Tel: +27 12 428 5333 • National 0800 722 700 • Fax: +27 12 428 5103  
 Web: www.nrcs.org.za

Doc No: 5337 E019 Rev: 07/03/2011

**"Protecting health, Safety, the Environment and ensuring Fair Trade"**

## Annexure F

### Arrangement of approval number

Example of the arrangement of an approval number for a swimming aid type:

**NRCS/9090/0004**

The above approval mark affixed to a swimming aid shows that the swimming aid type concerned has been approved under approval number NRCS/9090/0004. The approval number shows that this approval was granted in accordance with the requirements of the Compulsory Specification for swimming aids (with reference No. VC9090:2009) as published by Government Notice No. R. 91 (Government Gazette No. 31844) of 6 February 2009.

---

**14 Revision particulars**

Revision No.	Date of implementation	Nature of revision
-	-	-





No.:

Date: 07/03/2011

Page: 1 of 7

## 1. TYPE-IDENTIFYING INFORMATION

Name or trademark of the manufacturer, importer or supplier as marked on the type of swimming aid:

Type-identifying name or number:

APPLICATION	CLASS	according to SANS 53138-1, -2, -3					
		SIZE in kg					
		≤ 11	11 - 15	15 - 18	18 - 30	30 - 60	60 ≤
to introduce the wearer to the water, passive user (worn)	A						
to introduce the wearer to swimming strokes, active user (worn)	B						
to be held and to improve part of a stroke, active user (held)	C						

**For orientation only. Rough correlation body mass – age group:**  
 ≥ 11kg ≈ 1 year; 11 to 15kg ≈ 1 to 2 years; 15 to 18kg ≈ 2 to 3 years; 18 to 30kg ≈ 3 to 6 years; 30 to 60kg ≈ 6 to 12 years

## 2. GENERAL

### 2.1 Inspection method

- Type-examination of an application for the approval of a type of swimming aid in accordance with Divisional Procedure No. 5337 E019.
- Type-examination of an application for the extension of approval of a type of swimming aid in accordance with Divisional Procedure No. 5337 E019.
- Type-examination of an application for a Sales Permit for a type of swimming aid in accordance with Divisional Procedure No. REG 003.

## 2.2 Items required

	Included		Acceptable	
	Yes	No	Yes	No
<u>Application for approval</u>	<input type="checkbox"/>	<input type="checkbox"/>	<input type="checkbox"/>	<input type="checkbox"/>

Applicant has submitted the items as communicated to him by means of NRCS form No. VC9090-A.

**Remarks:**

## 3. TECHNICAL FILE

No.:

Inspection date(s):

### 3.1 Completeness and correctness of technical file in accordance with NRCS form No. VC9090-B

	Included		Acceptable	
	Yes	No	Yes	No
<b>B.1 Application form</b>	<input type="checkbox"/>	<input type="checkbox"/>	<input type="checkbox"/>	<input type="checkbox"/>

Application for approval

NRCS form No. VC9090-C.

*Note: The applicant shall be the manufacturer or importer of the type of swimming aid. The manufacturer or importer shall be an established legal entity within the Republic of South Africa.*

Application for a Sales Permit

Application form as set out in Divisional Procedure No. REG 003.

**Remarks:**

**B.2 Technical specifications**

A technical description supported by technical drawings of the type of swimming aid, indicating the following as a minimum:

- a) All component parts.
- b) Description of each component part.
- c) Material(s) used in each component part.  
*Note: See NRCS form No. VC9090-B5 for an example of a typical parts list & bill of materials for a product that will satisfy the aforementioned requirement.*
- d) Methods of assembly.  
*Note: See NRCS form No. VC9090-B4 for an example of a typical assembly diagram for a product that will satisfy the aforementioned requirement.*
- e) Markings and other information appearing on the type of swimming aid as required by the appropriate part of the latest edition of SANS 53138. The markings shall show the position intended for the approval number as required by paragraph 6 of the Compulsory Specification for swimming aids (herein referred to as VC9090:2009) as published by Government Notice No. R. 91 (Government Gazette No. 31844) of 6 February 2009.

*Note 1: The technical drawings shall be to scale. See NRCS form No. VC9090-B6 for an example of a typical technical drawing that will satisfy the aforementioned requirement.*

*Note 2: Photographic evidence may be included in the technical file in order to support the technical specifications.*

**Remarks:**

Included		Acceptable	
Yes	No	Yes	No

**B.3 Packaging**

<input type="checkbox"/>	<input type="checkbox"/>	<input type="checkbox"/>	<input type="checkbox"/>
--------------------------	--------------------------	--------------------------	--------------------------

Details of the marking of the packaging for the type of swimming aid as required by the appropriate part of the latest edition of SANS 53138.

*Remarks:*

**B.4 Information for users**

<input type="checkbox"/>	<input type="checkbox"/>	<input type="checkbox"/>	<input type="checkbox"/>
--------------------------	--------------------------	--------------------------	--------------------------

Instructions for use that shall accompany the type of swimming aid as required by the appropriate part of the latest edition of SANS 53138.

*Remarks:*

**B.5 Proof of compliance**

<input type="checkbox"/>	<input type="checkbox"/>	<input type="checkbox"/>	<input type="checkbox"/>
--------------------------	--------------------------	--------------------------	--------------------------

Copies of test reports demonstrating compliance with all the relevant requirements of the appropriate part of the latest edition of SANS 53138, ensuring that all component parts and sizes have been covered.

*Note 1: Only test reports from a testing authority that has been accredited in accordance with the latest edition of SANS 17025 by a signatory to the International Laboratory Accreditation Co-Operation's Mutual Recognition Agreement shall be accepted as proof of compliance with the safety requirements of SANS 53138. No approval certificates will be accepted.*  
*Note 2: Test reports shall satisfy the requirements of the latest edition of SANS 17025. See NRCS form No. VC9090-B1 for guidance.*

<i>Testing authority:</i> _____	<i>Test Report No.:</i> _____
<i>Testing authority:</i> _____	<i>Test Report No.:</i> _____
<i>Testing authority:</i> _____	<i>Test Report No.:</i> _____
<i>Testing authority:</i> _____	<i>Test Report No.:</i> _____

*Remarks:*

**B.6 Conformity of production & routine tests**

<input type="checkbox"/>	<input type="checkbox"/>	<input type="checkbox"/>	<input type="checkbox"/>
--------------------------	--------------------------	--------------------------	--------------------------

NRCS form No. VC9090-B3.

*Note: NRCS form No. VC9090-B2 must be consulted for the requirements for satisfactory arrangements in order to ensure effective control of the conformity of production in accordance with the provisions of VC9090:2009.*

*Remarks:*

**B.7 Other**

<input type="checkbox"/>	<input type="checkbox"/>	<input type="checkbox"/>	<input type="checkbox"/>
--------------------------	--------------------------	--------------------------	--------------------------

Any other materials that the applicant has included in the technical file and that were considered for the type-examination process.

*Remarks:*

**3.2 Suitability of technical file with respect to demonstrating compliance with paragraph 3.X of VC9090:2009**

The technical file was inspected for compliance with the requirements of SANS 53138-X:XXXX: 'Buoyant aids for swimming instruction, Part X: Safety requirements and test methods for xxxxxxxx xxxx xx xx xxxx'.

SANS 53138-X:XXXX Requirements	EXAMINATION OF TECHNICAL FILE	ACCEPTABLE	
		Yes	No
<b>5</b>	<b>Safety requirements</b> <i>Test report/s shall be examined for evidence of compliance.</i>		
<b>5.1</b>	<b>General</b>	<input type="checkbox"/>	<input type="checkbox"/>
<b>5.2</b>	<b>Buoyancy</b>		
<b>5.2.1</b>	<b>Buoyancy characteristics of the complete device</b>	<input type="checkbox"/>	<input type="checkbox"/>
<b>5.2.2</b>	<b>Residual buoyancy</b>	<input type="checkbox"/>	<input type="checkbox"/>
<b>5.3</b>	<b>Fit and positioning</b>		
<b>5.3.1</b>	<b>Adjustability – Class X devices</b>	<input type="checkbox"/>	<input type="checkbox"/>
<b>5.3.2</b>	<b>Security of buckles and other fixings</b>	<input type="checkbox"/>	<input type="checkbox"/>
<b>5.3.3</b>	<b>Retention of function</b>	<input type="checkbox"/>	<input type="checkbox"/>
<b>5.4</b>	<b>Safe design</b>		
<b>5.4.1</b>	<b>Edges, corners and points</b>	<input type="checkbox"/>	<input type="checkbox"/>
<b>5.4.2</b>	<b>Small parts</b>	<input type="checkbox"/>	<input type="checkbox"/>
<b>5.4.3</b>	<b>Migration of certain elements</b>	<input type="checkbox"/>	<input type="checkbox"/>
<b>5.5</b>	<b>Entire assembly and components</b>		
<b>5.5.1</b>	<b>Integrity of the entire assembly of worn devices</b>	<input type="checkbox"/>	<input type="checkbox"/>
<b>5.5.2</b>	<b>Thread</b>	<input type="checkbox"/>	<input type="checkbox"/>
<b>5.5.3</b>	<b>Valves and stoppers</b>	<input type="checkbox"/>	<input type="checkbox"/>
<b>5.6</b>	<b>Materials – mechanical properties</b>		
<b>5.6.1</b>	<b>Seam strength and durability of inflatable devices</b>	<input type="checkbox"/>	<input type="checkbox"/>
<b>5.6.2</b>	<b>Resistance to puncturing</b>	<input type="checkbox"/>	<input type="checkbox"/>
<b>5.6.3</b>	<b>Resistance of foam and other inherent buoyant material to water absorption</b>	<input type="checkbox"/>	<input type="checkbox"/>

SANS 53138- X:XXXX Requirements	EXAMINATION OF TECHNICAL FILE	ACCEPTABLE	
		Yes	No
5.6.4	Resistance of foam and other inherent buoyant materials to compression	<input type="checkbox"/>	<input type="checkbox"/>
5.7	<b>Materials and Markings – Chemical properties</b>		
5.7.1	Resistance to chlorinated salt water	<input type="checkbox"/>	<input type="checkbox"/>
5.7.2	Resistance of the markings to saliva	<input type="checkbox"/>	<input type="checkbox"/>
5.7.3	Resistance of the markings to perspiration	<input type="checkbox"/>	<input type="checkbox"/>
5.8	<b>Adhesion of markings</b>	<input type="checkbox"/>	<input type="checkbox"/>
7	<b>Warnings and markings on the product</b> <i>A technical description supported by technical drawings of the type of swimming aid, indicating the markings and other information appearing on the type of swimming aid, shall be examined for evidence of compliance.</i>	<input type="checkbox"/>	<input type="checkbox"/>
7.1	<b>Information supplied by the manufacturer</b> <i>Details of the marking of the packaging for the type of swimming aid and instructions for use that shall accompany the type of swimming aid shall be examined for evidence of compliance.</i>	<input type="checkbox"/>	<input type="checkbox"/>
7.2	<b>Consumer information at the point of sale</b> <i>Details of the marking of the packaging for the type of swimming aid shall be examined for evidence of compliance.</i>		
7.2.1		<input type="checkbox"/>	<input checked="" type="checkbox"/>
7.2.2		<input type="checkbox"/>	<input type="checkbox"/>

### 3.3 Suitability of technical file with respect to demonstrating compliance with paragraph 3.5 of VC9090:2009

ACCEPTABLE:	Yes	No
The information as recorded in NRCS form No. VC9090-B3 shall satisfy the requirements for satisfactory arrangements to ensure effective control of the conformity of production of the type of swimming aid as set out in NRCS form No. VC9090-B2.	<input type="checkbox"/>	<input type="checkbox"/>
<b>Remarks:</b>		

### 4. REFERENCE SAMPLE

No.: .....

Inspection date/s: .....

#### 4.1 Verification of production in accordance with technical file:

		Acceptable	
		Yes	No
<b>B.1</b>	<b>Application form</b>	<input type="checkbox"/>	<input type="checkbox"/>
Homogeneity of the reference sample with the product information as contained in the application form.			
<i>Remarks:</i>			
<b>B.2</b>	<b>Technical specifications</b>	<input type="checkbox"/>	<input type="checkbox"/>
Homogeneity of the reference sample with the technical specifications.			
<i>Remarks:</i>			
<b>B.3</b>	<b>Packaging</b>	<input type="checkbox"/>	<input type="checkbox"/>
Homogeneity of the reference sample with the marking of the packaging for the type of swimming aid.			
<i>Remarks:</i>			
<b>B.4</b>	<b>Information for users</b>	<input type="checkbox"/>	<input type="checkbox"/>
Homogeneity of the reference sample with the information as contained in the instructions for use that shall accompany the type of swimming aid.			
<i>Remarks:</i>			
<b>B.5</b>	<b>Proof of compliance</b>	<input type="checkbox"/>	<input type="checkbox"/>
Homogeneity of the reference sample with the information as contained in the test report/s.			
<i>Remarks:</i>			
<b>B.7</b>	<b>Other</b>	<input type="checkbox"/>	<input type="checkbox"/>
Homogeneity of the reference sample with any other materials that the applicant has included in the technical file and that were considered for the type-examination process.			
<i>Remarks:</i>			

#### 5. REMARKS

-

## 6. CONCLUSION

	Yes	No	N/A <sup>1</sup>
Technical file complete and correct in accordance with NRCS form No. VC9090-B:	<input type="checkbox"/>	<input type="checkbox"/>	<input type="checkbox"/>
Technical file satisfied the requirements of paragraph 3.X of VC9090:2009:	<input type="checkbox"/>	<input type="checkbox"/>	<input type="checkbox"/>
Technical file satisfied the requirements of paragraph 3.5 of VC9090:2009:	<input type="checkbox"/>	<input type="checkbox"/>	<input type="checkbox"/>
Reference sample manufactured in accordance with the technical file:	<input type="checkbox"/>	<input type="checkbox"/>	<input type="checkbox"/>
<b>Remarks:</b>			
Type of swimming aid recommended for approval in accordance with Annex A of VC9090:2009:	<input type="checkbox"/>	<input type="checkbox"/>	<input type="checkbox"/>
Type of swimming aid recommended for an extension of approval in accordance with paragraph 3.4 of VC9090:2009:	<input type="checkbox"/>	<input type="checkbox"/>	<input type="checkbox"/>
Type of swimming aid recommended for a Sales Permit in terms of Section 14(4) of the National Regulator for Compulsory Specifications Act, 2008 (Act No. 5 of 2008):	<input type="checkbox"/>	<input type="checkbox"/>	<input type="checkbox"/>
<b>Remarks:</b>			

\_\_\_\_\_  
MANAGER: APPROVALS  
NRCS CMM DIVISION

\_\_\_\_\_  
INSPECTOR  
NRCS CMM DIVISION

---oOo---

<sup>1</sup> Not applicable



Page: 1 of 2

Concerning: **APPROVAL GRANTED**

of a type of swimming aid pursuant to the Compulsory Specification for swimming aids as published by Government Notice No. R. 91 (Government Gazette No. 31844) of 6 February 2009.

Type approval No.: **NRCS/9090/**

Extension No.: **-**

**1. Type-identifying information**

Name or trademark of the manufacturer, importer or supplier as marked on the type of swimming aid:

Type-identifying name or number:

Buoyant aid for swimming instruction		according to SANS 53138-1, -2, -3					
APPLICATION	CLASS	SIZE in kg					
		≤ 11	11 - 15	15 - 18	18 - 30	30 - 60	60 ≤
to introduce the wearer to the water, passive user (worn)	A						
to introduce the wearer to swimming strokes, active user (worn)	B						
to be held and to improve part of a stroke, active user (held)	C						

**For orientation only. Rough correlation body mass – age group:**  
 ≥ 11kg ≈ 1 year; 11 to 15kg ≈ 1 to 2 years; 15 to 18kg ≈ 2 to 3 years; 18 to 30kg ≈ 3 to 6 years; 30 to 60kg ≈ 6 to 12 years

**2. Holder of the approval**

Name:

SARS Importers Code:

Address:

**3. South African National Standard applicable to the type of swimming aid**

SANS 53138-X:XXXX: 'Buoyant aids for swimming instruction, Part X: Safety requirements and test methods for xxxxxxxx xxxx xx xx xxxx'

**4. Terms and conditions of issue**

- 4.1 This certificate is applicable only to the type of swimming aid as identified in it.
- 4.2 The holder of the approval shall ensure that the approval number is marked on every swimming aid conforming to the type identified in this certificate, in print at least 6mm high and in the following format: RSA NRCS/9090/XXXX.
- 4.3 Every modification to the type of swimming aid itself, its control of conformity of production, its design and materials, marking, packaging material and information for users that shall accompany it when placed on the market as required by the appropriate South African National Standard, shall be formally notified accordingly to the NRCS prior to implementation.
- 4.4 The approval for the type of swimming aid identified in this certificate may be withdrawn at any time without prior notice if the requirements of the Compulsory Specification have not been maintained.

**5. Approval granted**

Place: **Pretoria**

Date: **04/03/2011**

T. Magolego (Mrs.)  
**Manager: Approvals**  
**NRCS CMM Division**



**Inspector**  
**NRCS CMM Division**

Head Office

SABS Campus 1 Dr Lategan Road Groenkloof Pretoria

✉ NRCS Private Bag X25, Brooklyn 0075

☎ Tel +27 12 428 5000 • Sharecall 0860 722 700 • Fax +27 12 428 5199

@ Web www.nrcs.org.za

**6. Manufacturer**

Name:

Address:

**7. Reference documents**

The following documents, bearing the type approval number shown below, are attached to this certificate:

- **Drawings, diagrams, plans and photographs of the type of swimming aid;**
- **Details of the marking of the type of swimming aid;**
- **Details of the marking of the packaging for the type of swimming aid;**
- **Information for users for the type of swimming aid;**
- **Minimum requirements for satisfactory arrangements to ensure effective control of the conformity of production for the type of swimming aid;**
- **Details of the body that will undertake control of conformity for the type of swimming aid;**
- **Details of the schedule for control of conformity for the type of swimming aid.**

---000---



Page: **1 of 2**

Concerning: **APPROVAL EXTENDED**

of a type of swimming aid pursuant to the Compulsory Specification for swimming aids as published by Government Notice No. R. 91 (Government Gazette No. 31844) of 6 February 2009.

Type approval No.: **NRCS/9090/**

Extension No.: \_\_\_\_\_

**1. Type-identifying information**

Name or trademark of the manufacturer, importer or supplier as marked on the type of swimming aid:

Type-identifying name or number:

APPLICATION	CLASS	according to SANS 53138-1, -2, -3					
		SIZE in kg					
		≤ 11	11 - 15	15 - 18	18 - 30	30 - 60	60 ≤
to introduce the wearer to the water, passive user (worn)	A						
to introduce the wearer to swimming strokes, active user (worn)	B						
to be held and to improve part of a stroke, active user (held)	C						

**For orientation only. Rough correlation body mass – age group:**  
 ≥ 11kg ≈ 1 year; 11 to 15kg ≈ 1 to 2 years; 15 to 18kg ≈ 2 to 3 years; 18 to 30kg ≈ 3 to 6 years; 30 to 60kg ≈ 6 to 12 years

**2. Holder of the approval**

Name:

SARS Importers Code:

Address:

**3. South African National Standard applicable to the type of swimming aid**

SANS 53138-X:XXXX: 'Buoyant aids for swimming instruction, Part X: Safety requirements and test methods for xxxxxxxx xxxx xx xx xxxx'

**4. Terms and conditions of issue**

- 4.1 This certificate is applicable only to the type of swimming aid as identified in it.
- 4.2 The holder of the approval shall ensure that the approval number is marked on every swimming aid conforming to the type identified in this certificate, in print at least 6mm high and in the following format: RSA NRCS/9090/XXXX.
- 4.3 Every modification to the type of swimming aid itself, its control of conformity of production, its design and materials, marking, packaging material and information for users that shall accompany it when placed on the market as required by the appropriate South African National Standard, shall be formally notified accordingly to the NRCS prior to implementation.
- 4.4 The approval for the type of swimming aid identified in this certificate may be withdrawn at any time without prior notice if the requirements of the Compulsory Specification have not been maintained.

**5. Approval extended**

Place: **Pretoria**

Date: **04/03/2011**

T. Magolego (Mrs.)  
**Manager: Approvals**  
**NRCS CMM Division**



**Inspector**  
**NRCS CMM Division**

Head Office

SABS Campus 1 Dr Lategan Road Groenkloof Pretoria

✉ NRCS Private Bag X25, Brooklyn 0075

☎ Tel +27 12 428 5000 • Sharecall 0860 722 700 • Fax +27 12 428 5199

@ Web www.nrcs.org.za

6. **Manufacturer**

Name:

Address:

7. **Reference documents**

The following documents, bearing the type approval number shown below, are attached to this certificate:

---oOo---

CLASS	APPLICATION
A	to introduce the waste to the water passive user
B	to introduce the waste to swimming strokes, active user
C	to be fitted and to improve part of a stroke, active user

Holder of the approval

Name

SARS Reference Code

Address

South African National Standards applicable to the type of swimming aid

SANS 5015 X-XXXX - Buyout aids for swimming instruction, Part X: Safety requirements and test methods for strokes, class X, etc.

Terms and conditions of issue

This certificate is specific only to the type of swimming aid as identified in it

The holder of the approval shall ensure that the approval number is marked on every swimming aid conforming to the type identified in this certificate

in the at least form right and in the following format: RSA NRCS000XXXX

Every production of the type of swimming aid shall be under the control of conformity of production (design and materials, marking, packaging, materials, etc.)

Information for users that shall accompany it when placed on the market as required by the applicable South African National Standards shall be

formally notified accordingly to the NRCS and its implementation

The approval for the type of swimming aid identified in this certificate may be withdrawn any time without prior notice if the requirements of the

Compulsory Specifications have not been met

Approval extended

to



T. Magoogo (Mr.)

Manager, Approvals

NRCS CMM Division

Inspector  
NRCS CMM Division